

<small>EGENDOM BEWAKEN BY SOMEREN VERMENNIGVING OF AFDERLING AAN DEREN IN WELKE VORM DAN OOK IS ZONDER SCHRIFTELIJKE TOESTEMMING VAN EIGENARES NIET GEORLOFD.</small>	TOLERANTIES ALGEMEEN. * Herkenningmaat / mal Maattolerantie ± 0.5 mm Hoektolerantie ± 0.5°	MATERIAAL. Diversen BENAMING.	SCHAAL / MAATEENHEID millimeter [mm]
	AMERIKAANSE PROJECTIE A3	Varidoors Solide Geluidwerend Automaat Solide - Solide Geluidwerend Automaat WD150 Varidoors	TEKENAAR / DATUM John Belemans 3-12-2024
VARI-DOORS SCHUIFDEURSYSTEMEN	Revisienr. Omschrijving 02 Nieuwe automaat Metaflex 01 Diversen	Datum 1-4-2025 19-11-2024	Naam JBEL JBEL
		TEKENINGNUMMER AL001-850-02	REF. AL001-850-02

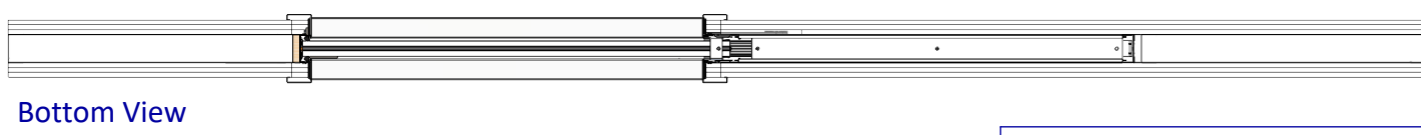

2x Laag Gips = wd 125mm
3x Laag Gips = wd 150mm

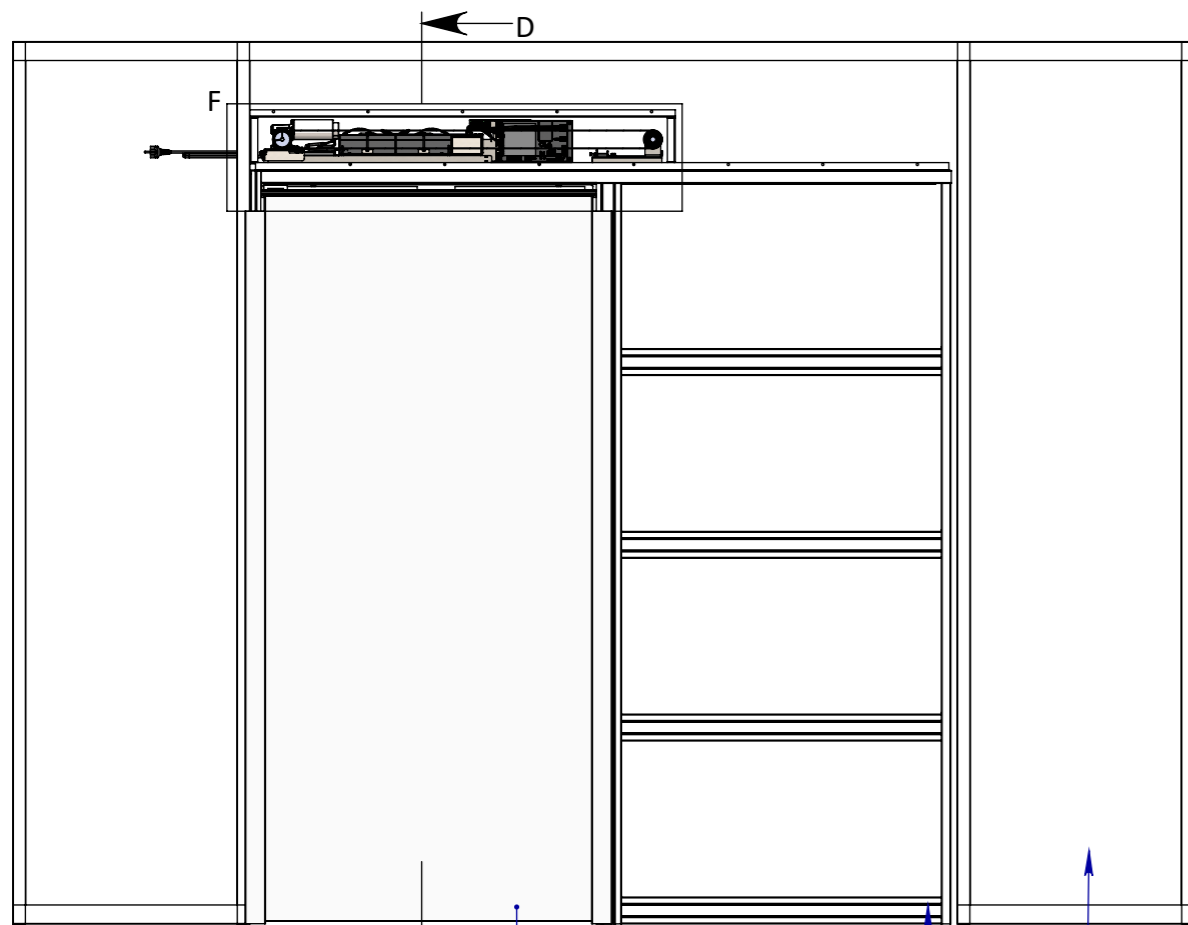

Front View

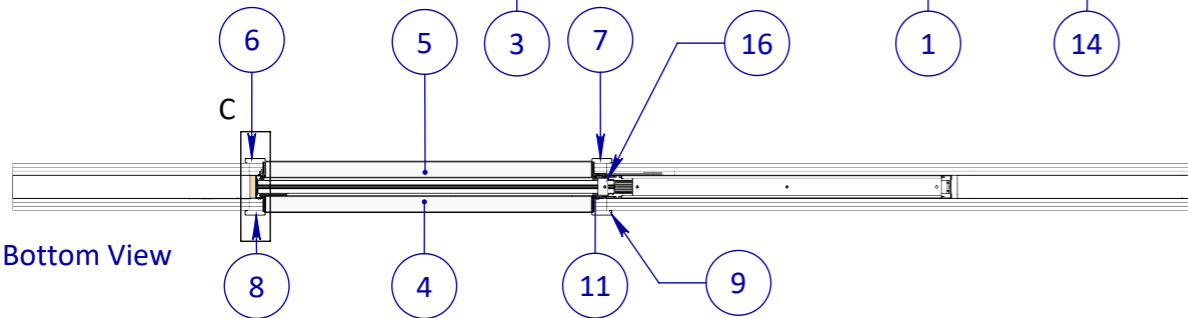

Bottom View

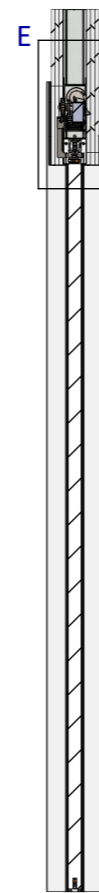

SECTION D-D

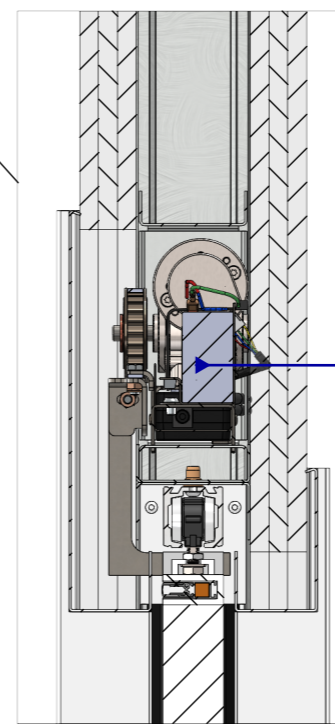

DETAIL E

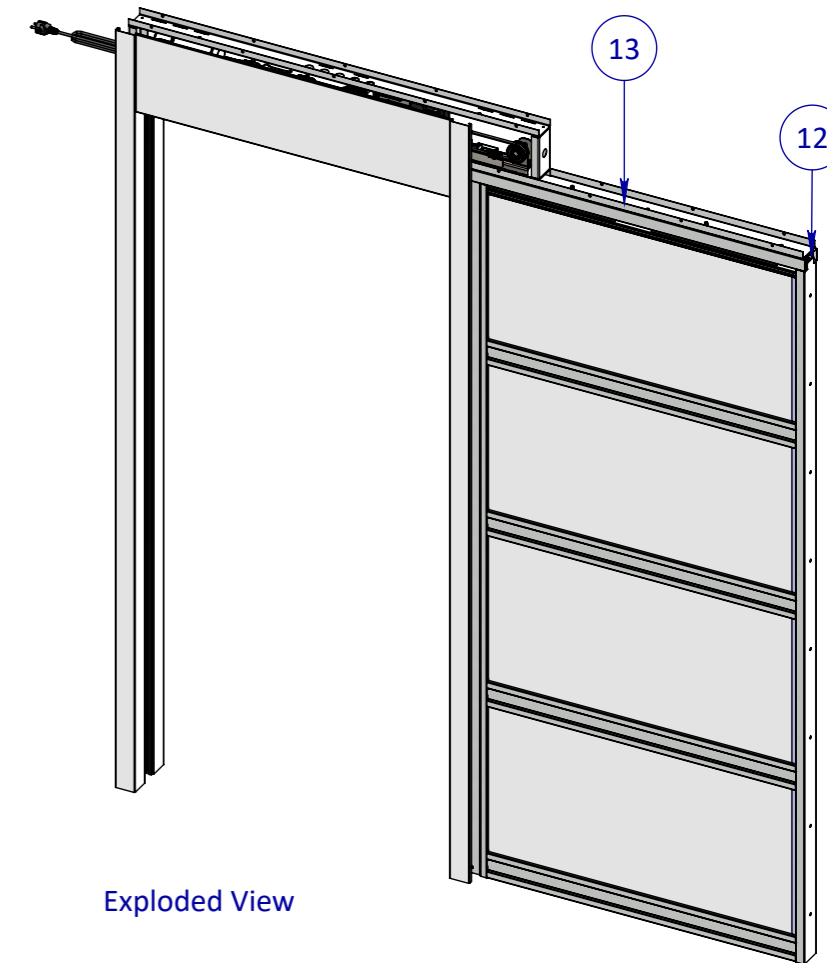

Exploded View

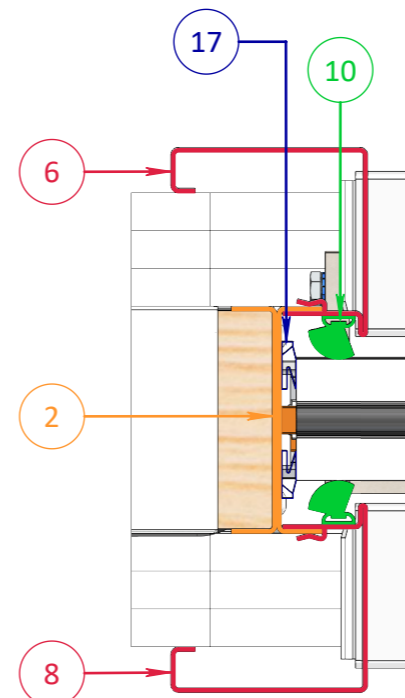

DETAIL C

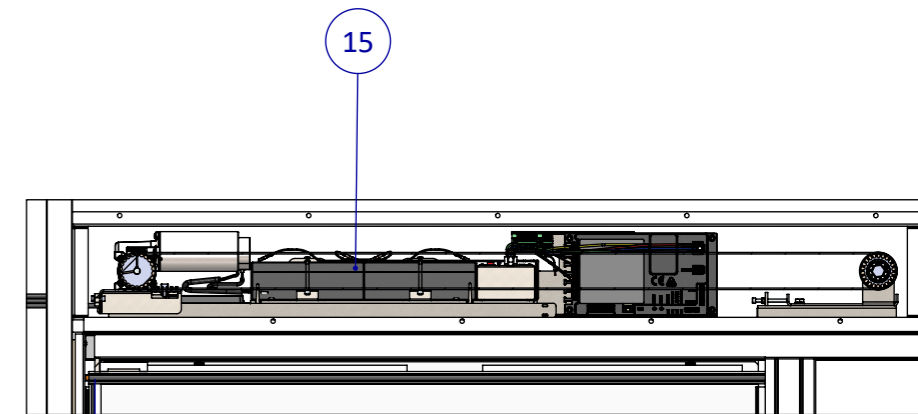

DETAIL F

Meeneembeugel >
kopse kant deur = ±10mm

Posnr.	Aantal	Omschrijving	Tekeningnr	Config.Omschr.
1	1	Nis Standaard		1110x2315 Zonder sluitstijl Volledig wegschuivend
2	1	Assembly Sluitstijl		Standaard
3	1	Deur Configuratie		Geluidwerend IDW
4	1	Horizontale lijst	PHVD232	WD150 std
5	1	Horizontale lijst	PHVD241	WD150 automaat
6	1	Verticale lijst	PHVD234	Automaat WD150 Rechts
7	1	Verticale lijst	PHVD234	Automaat WD150 Links
8	1	Verticale lijst WD150	PHVD 227	Rechts L=2400mm
9	1	Verticale lijst WD150	PHVD 227	Links L=2400mm
10	2	Borstel Standaard		L=2310mm Enkelzijdig
11	2	Borstel Standaard		L=2217mm Enkelzijdig
12	2	M4.2x13 Panhead flange		DIN 968
13	1	Brug Automaat volledig wegschuivend		Geluidwerend
14	1	Unistrut Wand Automaat		Automaat Geluidwerend voledig wegschuivend WD150
15	1	Automaat Compleet Links/Rechts		Rechts [Nieuw]
16	2	Geluidwerend D-Rubber Config.		L=2205mm
17	2	Geluidwerend Rubber profiel sluitstijl		L=2300mm
18	2	M6x16 Countersunk Cross Recessed		B18.6.7M
19	6	M5.0x50 Tapping screw		DIN 7982

EGENDOM BEWAKEN BY SOMEREN.
VERNIEUWING OF AANDEKING
VAN DELEN IN WELKE VORMDAN OOK
IS ZONDER SCHRIFTELIJKE TOESTEMMING
VAN EIGENARES NIET GEORLOOFT.

TOLERANTIES ALGEMEEN.
* Herkeningsmaal / mal
Maattolerantie ± 0.5 mm
Hoektolerantie ± 0.5°

AMERIKAANSE PROJECTIE
A3

VARI-DOORS
SCHUIFDEURSYSTEMEN

MATERIAAL. Diversen	SCHAAL / MAATEENHEID	
BENAMING.	millimeter [mm]	
Varidoors Solide Geluidwerend Automaat	TEKENAAR / DATUM	
Solide - Solide Geluidwerend Automaat WD150	John Belemans	
Varidoors	3-12-2024	
Revisienr. Omschrijving	Datum	Naam
02 Nieuwe automaat Metaflex	1-4-2025	JBEL
01 Diversen	19-11-2024	JBEL
TEKENINGNUMMER		
AL001-850-02		
REF. AL001-850-02		